

Product name	Description	Version
LS20030	GPS smart antenna module/USB,9600BPS,30x30mm	1.0
LS20031	GPS smart antenna module/TTL,9600BPS,30x30mm	
LS20032	GPS smart antenna module/RS232,9600BPS,30x30mm	
LS20033	GPS smart antenna module/TTL,9600BPS,35x16mm	

Datasheet of GPS smart antenna module, LS20030~3

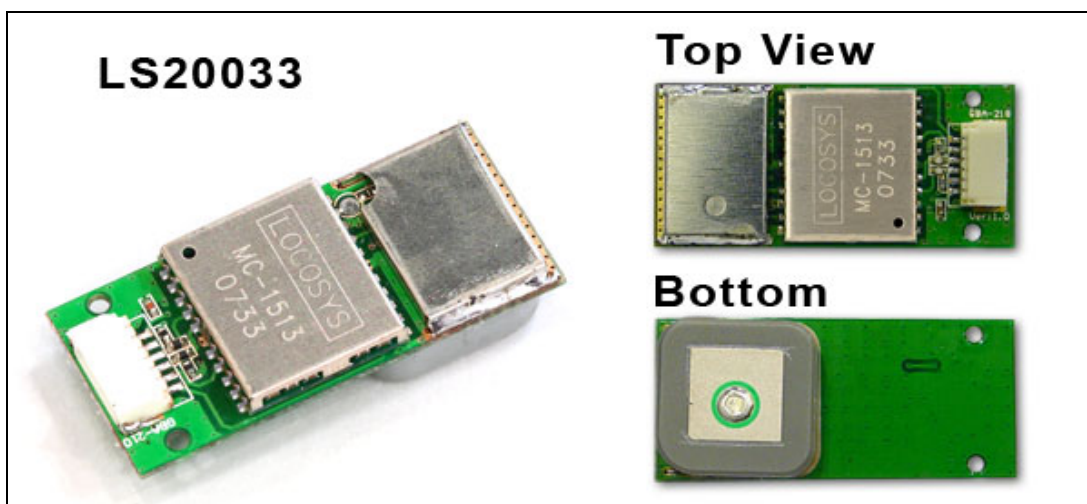
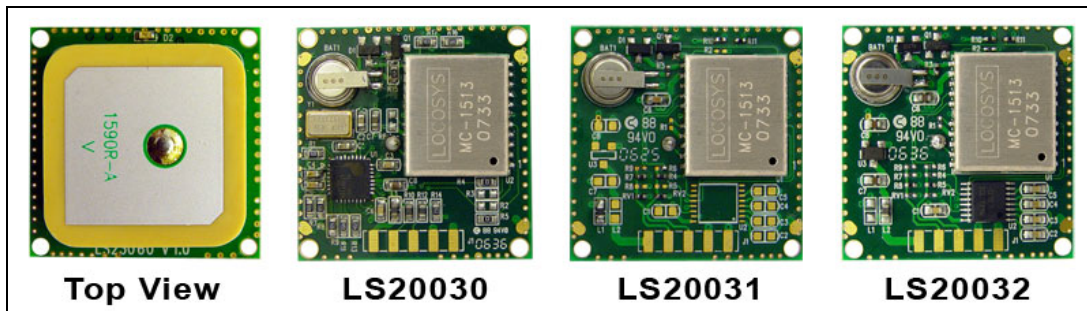

1 Introduction

LS20030~3 series products are complete GPS smart antenna receivers, including an embedded antenna and GPS receiver circuits, designed for a broad spectrum of OEM system applications. The product is based on the proven technology found in LOCOSYS 32 channel GPS SMD type receivers MC-1513 that use MediaTek chip solution. The GPS smart antenna will track up to 32 satellites at a time while providing fast time-to-first-fix, one-second navigation update and low power consumption. It can provide you with superior sensitivity and performance even in urban canyon and dense foliage environment. Its far-reaching capability meets the sensitivity requirements of car navigation as well as other location-based applications.

2 Features

- MediaTek MT3318 solution
- Support 32-channel GPS

- Fast TTFF at low signal level
- Up to 5 Hz update rate
- Capable of SBAS (WAAS, EGNOS, MSAS)
- Build-in micro battery to reserve system data for rapid satellite acquisition (not in LS20033)
- LED indicator for GPS fix or not fix (not in LS20033)

3 Application

- Personal positioning and navigation
- Automotive navigation
- Marine navigation

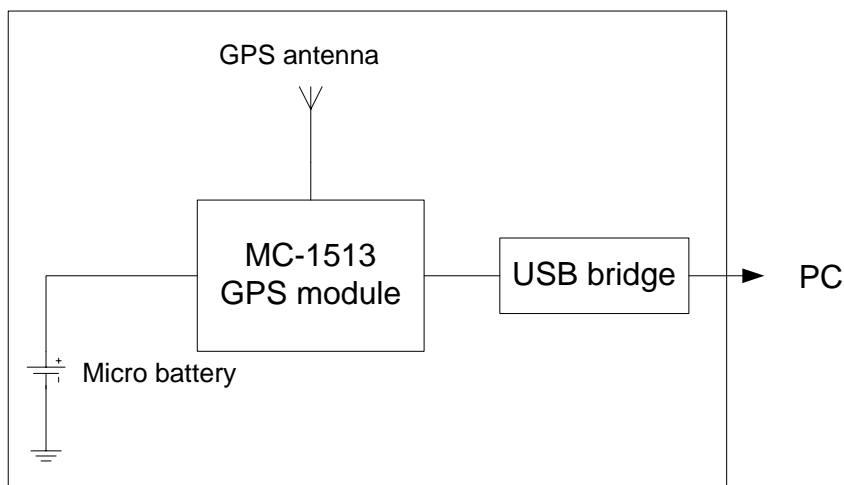

Fig 3-1 System block diagram of LS20030

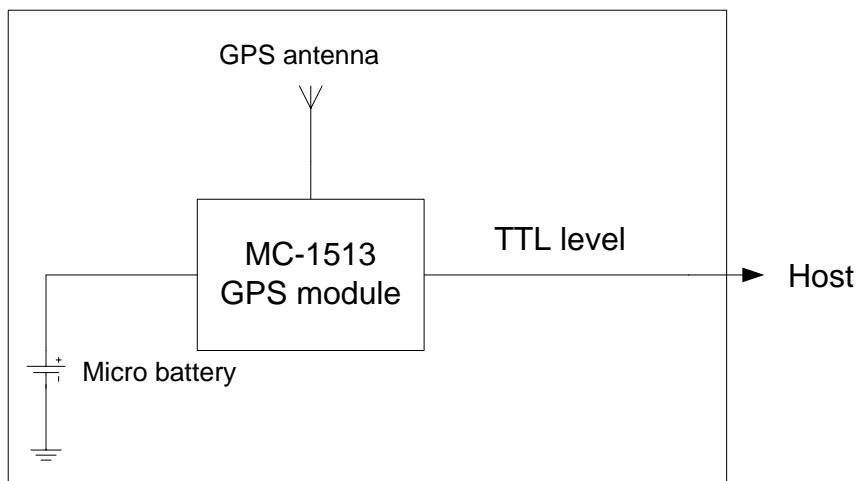

Fig 3-2 System block diagram of LS20031

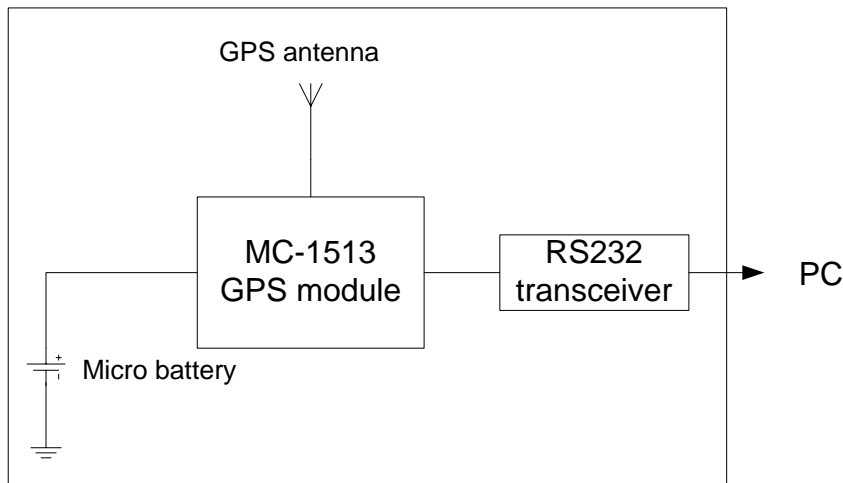

Fig 3-3 System block diagram of LS20032

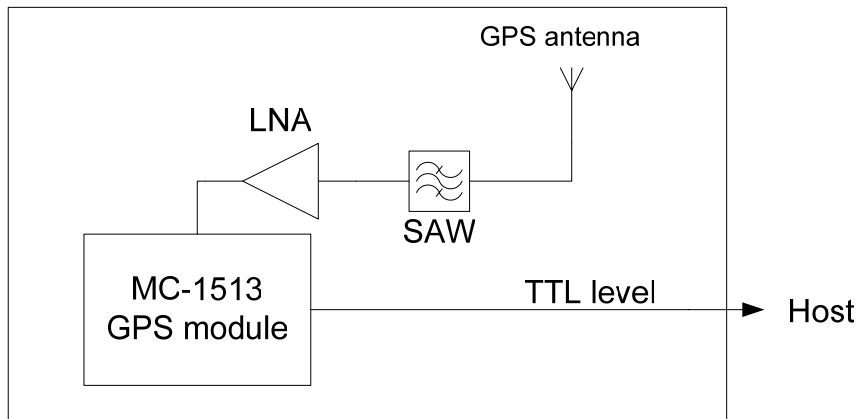

Fig 3-4 System block diagram of LS20033

4 GPS receiver

Chip	MediaTek MT3318	
Frequency	L1 1575.42MHz, C/A code	
Channels	Support 32 channels	
Update rate	1Hz default, up to 5Hz	
Acquisition Time	Hot start (Open Sky)	2s (typical)
	Cold Start (Open Sky)	36s (typical)
Position Accuracy	Autonomous	3m (2D RMS)
	SBAS	2.5m (depends on accuracy of correction data)
Datum	WGS-84 (default)	
Max. Altitude	< 18,000 m	
Max. Velocity	< 515 m/s	

Protocol Support	NMEA 0183 ver 3.01	9600 bps, 8 data bits, no parity, 1 stop bits (default) 1Hz: GGA, GLL, GSA, GSV, RMC, VTG
------------------	--------------------	----------------------------------------------------------------------------------------------

5 Software interface

5.1 NMEA output message

Table 5.1-1 NMEA output message

NMEA record	Description
GGA	Global positioning system fixed data
GLL	Geographic position - latitude/longitude
GSA	GNSS DOP and active satellites
GSV	GNSS satellites in view
RMC	Recommended minimum specific GNSS data
VTG	Course over ground and ground speed

● GGA--- Global Positioning System Fixed Data

Table 5.1-2 contains the values for the following example:

\$GPGGA,053740.000,2503.6319,N,12136.0099,E,1,08,1.1,63.8,M,15.2,M,,0000*64

Table 5.1-2 GGA Data Format

Name	Example	Units	Description
Message ID	\$GPGGA		GGA protocol header
UTC Time	053740.000		hhmmss.sss
Latitude	2503.6319		ddmm.mmmm
N/S indicator	N		N=north or S=south
Longitude	12136.0099		dddmm.mmmm
E/W Indicator	E		E=east or W=west
Position Fix Indicator	1		See Table 5.1-3
Satellites Used	08		Range 0 to 12
HDOP	1.1		Horizontal Dilution of Precision
MSL Altitude	63.8	mters	
Units	M	mters	
Geoid Separation	15.2	mters	
Units	M	mters	
Age of Diff. Corr.		second	Null fields when DGPS is not used
Diff. Ref. Station ID	0000		
Checksum	*64		
<CR> <LF>			End of message termination

Table 5.1-3 Position Fix Indicators

Value	Description
0	Fix not available or invalid
1	GPS SPS Mode, fix valid
2	Differential GPS, SPS Mode, fix valid
3-5	Not supported
6	Dead Reckoning Mode, fix valid

● GLL--- Geographic Position – Latitude/Longitude

Table 5.1-4 contains the values for the following example:

\$GPGLL,2503.6319,N,12136.0099,E,053740.000,A,A*52

Table 5.1-4 GLL Data Format

Name	Example	Units	Description
Message ID	\$GPGLL		GLL protocol header
Latitude	2503.6319		ddmm.mmmmm
N/S indicator	N		N=north or S=south
Longitude	12136.0099		dddmm.mmmmm
E/W indicator	E		E=east or W=west
UTC Time	053740.000		hhmmss.sss
Status	A		A=data valid or V=data not valid
Mode	A		A=autonomous, D=DGPS, E=DR
Checksum	*52		
<CR> <LF>			End of message termination

● GSA---GNSS DOP and Active Satellites

Table 5.1-5 contains the values for the following example:

\$GPGSA,A,3,24,07,17,11,28,08,20,04,,,,,2.0,1.1,1.7*35

Table 5.1-5 GSA Data Format

Name	Example	Units	Description
Message ID	\$GPGSA		GSA protocol header
Mode 1	A		See Table 5.1-6
Mode 2	3		See Table 5.1-7
ID of satellite used	24		Sv on Channel 1
ID of satellite used	07		Sv on Channel 2
....		
ID of satellite used			Sv on Channel 12
PDOP	2.0		Position Dilution of Precision

HDOP	1.1		Horizontal Dilution of Precision
VDOP	1.7		Vertical Dilution of Precision
Checksum	*35		
<CR> <LF>			End of message termination

Table 5.1-6 Mode 1

Value	Description
M	Manual- forced to operate in 2D or 3D mode
A	Automatic-allowed to automatically switch 2D/3D

Table 5.1-7 Mode 2

Value	Description
1	Fix not available
2	2D
3	3D

● GSV---GNSS Satellites in View

Table 5.1-8 contains the values for the following example:

\$GPGSV,3,1,12,28,81,285,42,24,67,302,46,31,54,354,,20,51,077,46*73

\$GPGSV,3,2,12,17,41,328,45,07,32,315,45,04,31,250,40,11,25,046,41*75

\$GPGSV,3,3,12,08,22,214,38,27,08,190,16,19,05,092,33,23,04,127,*7B

Table 5.1-8 GSV Data Format

Name	Example	Units	Description
Message ID	\$GPGSV		GSV protocol header
Total number of messages ¹	3		Range 1 to 3
Message number ¹	1		Range 1 to 3
Satellites in view	12		
Satellite ID	28		Channel 1 (Range 01 to 32)
Elevation	81	degrees	Channel 1 (Range 00 to 90)
Azimuth	285	degrees	Channel 1 (Range 000 to 359)
SNR (C/No)	42	dB-Hz	Channel 1 (Range 00 to 99, null when not tracking)
Satellite ID	20		Channel 4 (Range 01 to 32)
Elevation	51	degrees	Channel 4 (Range 00 to 90)
Azimuth	077	degrees	Channel 4 (Range 000 to 359)
SNR (C/No)	46	dB-Hz	Channel 4 (Range 00 to 99, null when not tracking)
Checksum	*73		
<CR> <LF>			End of message termination

1. Depending on the number of satellites tracked multiple messages of GSV data may be required.

● RMC---Recommended Minimum Specific GNSS Data

Table 5.1-9 contains the values for the following example:

\$GPRMC,053740.000,A,2503.6319,N,12136.0099,E,2.69,79.65,100106,,A*53

Table 5.1-9 RMC Data Format

Name	Example	Units	Description
Message ID	\$GPRMC		RMC protocol header
UTC Time	053740.000		hhmmss.sss
Status	A		A=data valid or V=data not valid
Latitude	2503.6319		ddmm.mmmm
N/S Indicator	N		N=north or S=south
Longitude	12136.0099		dddmm.mmmm
E/W Indicator	E		E=east or W=west
Speed over ground	2.69	knots	True
Course over ground	79.65	degrees	
Date	100106		ddmmyy
Magnetic variation		degrees	
Variation sense			E=east or W=west (Not shown)
Mode	A		A=autonomous, D=DGPS, E=DR
Checksum	*53		
<CR> <LF>			End of message termination

● VTG---Course Over Ground and Ground Speed

Table 5.1-10 contains the values for the following example:

\$GPVTG,79.65,T,,M,2.69,N,5.0,K,A*38

Table 5.1-10 VTG Data Format

Name	Example	Units	Description
Message ID	\$GPVTG		VTG protocol header
Course over ground	79.65	degrees	Measured heading
Reference	T		True
Course over ground		degrees	Measured heading
Reference	M		Magnetic
Speed over ground	2.69	knots	Measured speed
Units	N		Knots
Speed over ground	5.0	km/hr	Measured speed
Units	K		Kilometer per hour
Mode	A		A=autonomous, D=DGPS, E=DR
Checksum	*38		

<CR> <LF>			End of message termination
-----------	--	--	----------------------------

5.2 Proprietary NMEA input message

Please refer to MTK proprietary message.

6 LED indicator

The red LED is an indicator of GPS positioning status. In continuous power mode, it flashes once per second when position is fixed. Otherwise it is off. The timing in detail is as below.

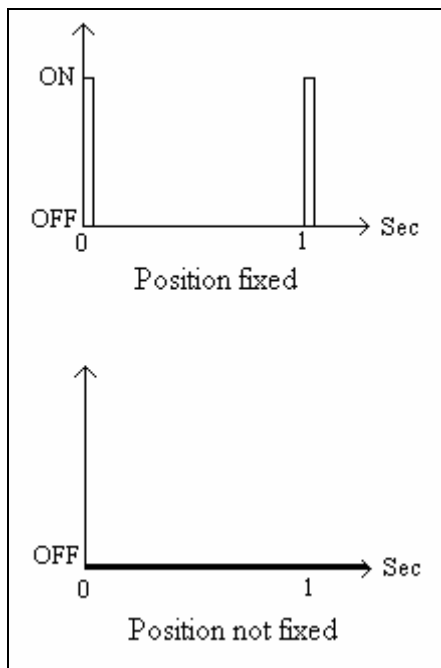

Fig 6.1 LED indicator of GPS positioning status

7 Pin assignment and descriptions

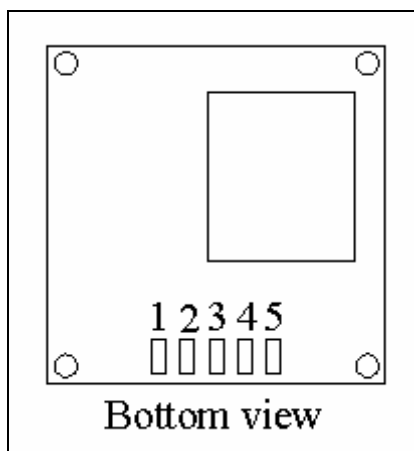

Fig 7.1 Pin assignment of LS20030, LS20031 and LS20032

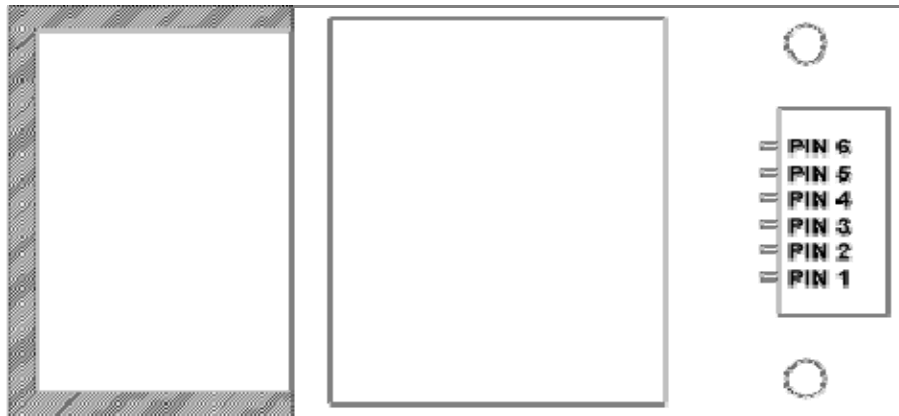

Fig 7.2 Pin assignment of LS20033

● **LS20030**

Pin #	Name	Type	Description
1	VBUS	P	USB power input
2	D-		D- line
3	D+		D+ line
4	GND	P	Ground
5	Shield	P	Ground

● **LS20031**

Pin #	Name	Type	Description
1	VCC	P	Power input
2	RX	I	Data input (TTL level)
3	TX	O	Data output (TTL level)
4	GND	P	Ground
5	GND	P	Ground

● **LS20032**

Pin #	Name	Type	Description
1	VCC	P	Power input
2	RX	I	Data input (RS232 level)
3	TX	O	Data output (RS232 level)
4	GND	P	Ground
5	GND	P	Ground

● **LS20033**

Pin #	Name	Type	Description
-------	------	------	-------------

1	VCC	P	Power input
2	GND	P	Ground
3	TX	O	Data output (TTL level)
4	RX	I	Data input (TTL level)
5	GPS LED	O	LED indicator. See Fig 6.1
6	VBACKUP	P	Backup battery supply voltage

8 DC & Temperature characteristics

8.1 DC Electrical characteristics

Parameter	Symbol	Product	Min.	Typ.	Max.	Units
Input voltage	VCC	LS20030	4.75	5	5.25	V
		LS20031	3	3.3	4.2	
		LS20032	4	5	6	
		LS20033	3	3.3	4.2	
Input Backup Battery Voltage	VBACKUP	LS20033	1.1		6.0	V
Input current	I _{cc}	LS20030		47 ⁽¹⁾		mA
		LS20031		41 ⁽¹⁾		
		LS20032		46 ⁽¹⁾		
		LS20033		44 ⁽¹⁾		
High Level Input Voltage	V _{IH}	LS20031	2.0		3.6	V
		LS20033				
Low Level Input Voltage	V _{IL}	LS20031	-0.3		0.8	V
		LS20033				
High Level Input Current	I _{IH}	LS20031	-1		1	uA
		LS20033				
Low Level Input Current	I _{IL}	LS20031	-1		1	uA
		LS20033				
High Level Output Voltage	V _{OH}	LS20031	2.4			V
		LS20033				
Low Level Output Voltage	V _{OL}	LS20031			0.4	V
		LS20033				
High Level Output Current	I _{OH}	LS20031		2		mA
		LS20033				
Low Level Output Current	I _{OL}	LS20031		2		mA
		LS20033				

1. Measured in several seconds after position fix is available and tracked GPS signals are equal to or more than 6. If GPS almanac data was fully received and GPS satellites are stable, this value may reduce 8mA.

8.2 Temperature characteristics

Parameter	Symbol	Product	Min.	Typ.	Max.	Units
Operating Temperature	Topr	LS20030~LS20032	-30	-	85	°C
		LS20033	-20	-	65	
Storage Temperature	Tstg	LS20030~LS20032	-40	25	85	°C
		LS20033	-30	-	75	

9 Mechanical specification

- LS20030, LS20031, LS20032

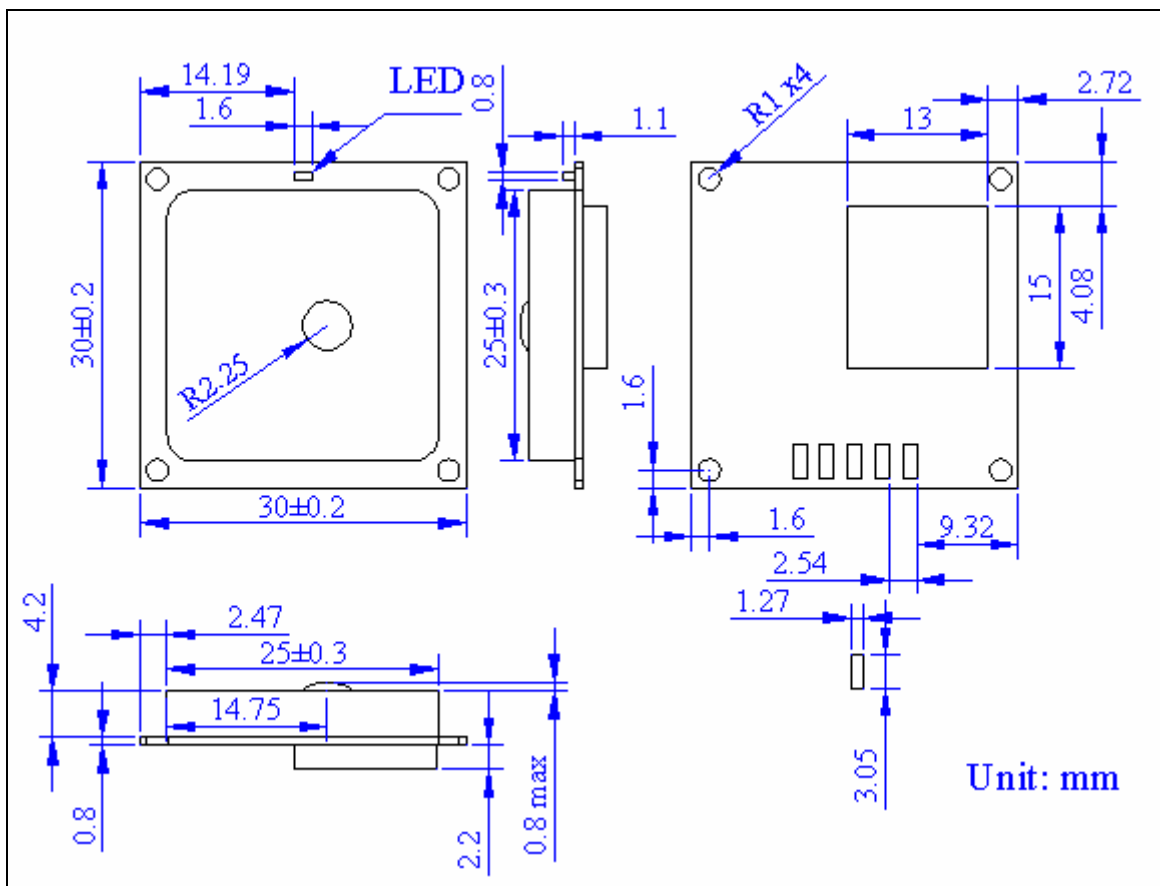

● LS20033

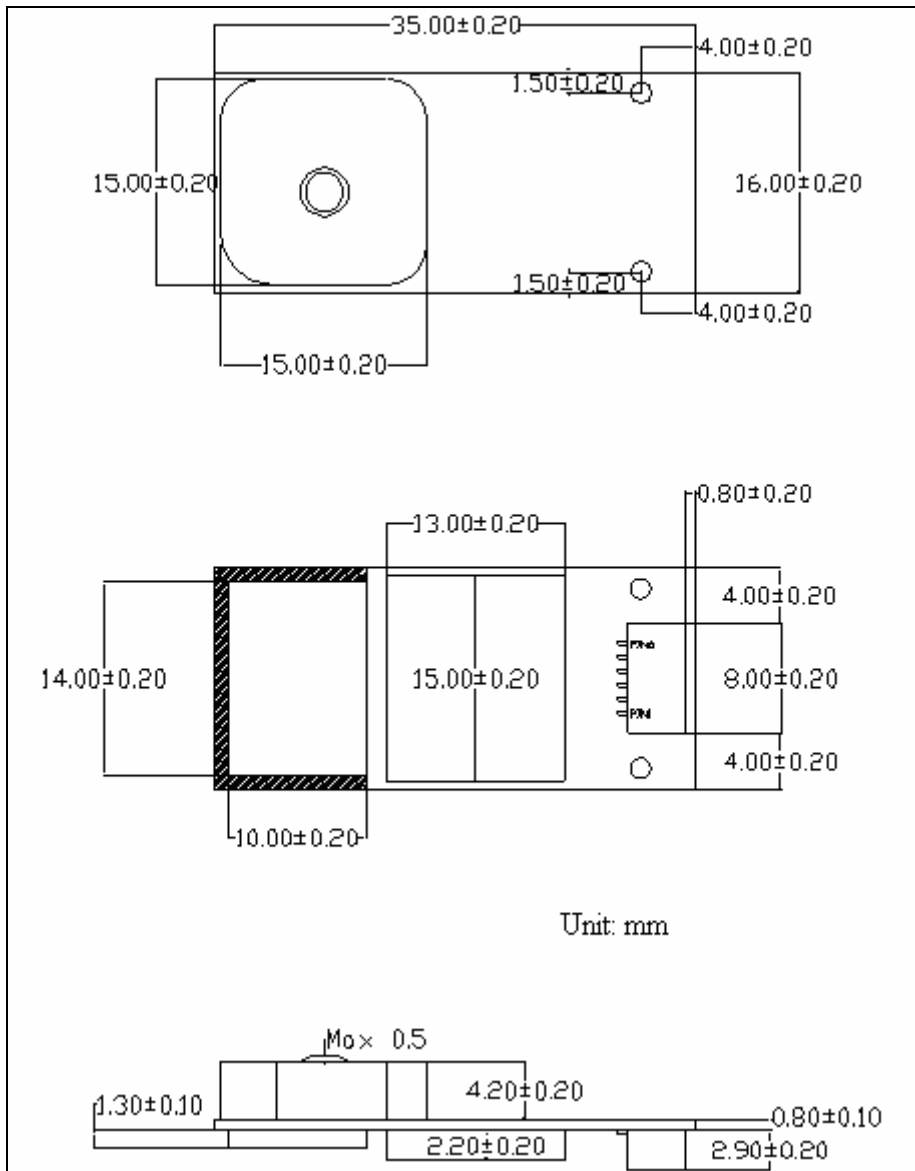

The 6-pin connector is belonging to Wafer series connector and its pitch is 1.0mm. There is a supplier called Cherng Weei Technology Corp. <http://www.cwe.com.tw> and its part number is CSH-W10R-06TR for you reference.

Document change list

Revision 1.0

- First release on Oct. 25, 2007.